

OPERATING INSTRUCTIONS  
for the  
Pump Drive BVP-BP for centrifugal blood pump heads  
BP-50/BP-80 and SP-45

(Revision 1.0 / 6 / 00 / Steiert, translation: Linton)

## Contents

Introduction, manufacturer's details .....	2
Copyright .....	2
Trademarks .....	2
Preliminary notes on the pump system .....	2
Read these Operating Instructions! .....	2
Range of application and safety precautions .....	2
Warning note .....	3
Warranty .....	3
List of items supplied .....	3
Operating panel .....	4
Back of unit .....	4
Supply voltage .....	4
Altering the supply voltage 115V/230V and changing the fuses .....	5
Starting up .....	5
Switching on .....	5
Analogue interface connector .....	6
Internal adjustments .....	6
Centrifugal pump heads .....	7
Pump head BP-50 and BP-80 .....	7
Output characteristic of a BP-80 .....	8
Fitting and removing the BP-80 .....	8
Pump head SP-45 .....	9
Output characteristic of SP-45 .....	9
Fitting the adapter SP-03 for head SP-45 .....	10
Inserting the pump head SP-45 .....	10
Operating notes .....	11
Repairs .....	11
Spares .....	11
Maintenance and cleaning .....	11
Technical data .....	11
Reply form .....	12
Index .....	13

**Introduction, manufacturer's details**

These Operating Instructions describe the function and the use of the pump drive BVP-BP. They represent an essential part of the apparatus and must be kept close to the apparatus, accessible to all users.

All the information in these Instructions has been assembled after careful examination but does not represent any warranty of product properties. Alterations in line with technical progress are reserved.

HSE-HARVARD obtains the basic unit of the drive from Ismatec and modifies it so that the Bio-Pump(R) centrifugal blood pump heads BP-50 and BP-80 by Medtronic can be used, as well as the pump head SP-45 by Terumo (using a suitable adapter).

Responsible for the modified drive:

HUGO SACHS ELEKTRONIK -  
HARVARD APPARATUS GmbH,  
Gruenstr. 1,  
79232 March-Hugstetten,  
Germany.

Phone Germany: 07665/9200-0  
abroad: (int + 49) 7665 9200 0  
Fax Germany: 07665/9200-90  
abroad: (int + 49) 7665 9200 90  
e-mail: HSEMain@aol.com  
Internet: <http://www.hugo-sachs.de>

**Copyright**

This product and the corresponding documentation are protected by copyright. All rights reserved. This document must not be copied, photocopied, reproduced or translated, either as a whole or in parts, without prior written agreement by Hugo Sachs Elektronik - HARVARD APPARATUS GmbH, March-Hugstetten, Germany.

**Trademarks**

Ismatec® is a registered trademark of Ismatec SA, Glattburg-Zurich, Switzerland. Other trademarks referred to in these Operating Instructions are the property of the corresponding applicants.

**Preliminary notes on the pump system**

The complete pump system consists of the pump drive BVP-BP and a centrifugal pump head BP-50 or BP-80 (Medtronic) or SP-45 with adapter SP-03 (Terumo). The action of the pump heads ensures very gentle pumping of blood. Each head forms a completely enclosed unit without any moving parts to the outside. Pump head and drive are linked by a magnetic coupling. The driving motor turns a magnet which transmits the rotation to another magnet located inside the pump head.

The pump heads have a limited life. The pump head mounting is therefore so arranged that the heads can be replaced without the use of tools.

**Read these Operating Instructions!**

We recommend that you carefully read this Instruction Manual and adhere fully to the information contained in it.

We accept no responsibility for any damage caused by inappropriate handling.

**Range of application and safety precautions**

The pumps are intended for liquid handling in laboratory and industry. We take it for granted that the GLP (Good Laboratory Practice) guidelines are observed as well as the recommendations given below.

- The electrical circuit between supply and pump must be earthed.
- The pump must only be operated within the given operating and ambient conditions.
- Do not position the pump closer than 10 cm from a wall and ensure that the ventilation apertures are not obstructed.
- Only new fuses conforming to the details on page 4 must be used.
- The fuse holder must not be bridged (short-circuited).
- During operation the casing must not be opened or removed.
- Any repairs must only be carried out by a qualified person fully aware of the potential hazards.
- Any work carried out on and inside the unit by customers or third persons is undertaken on their own responsibility.

**The pump must not be used:**

- **for medical applications on humans**
- **in hazardous (Ex) areas and in the presence of flammable gases and vapours.**

**Warning note**

In the operation of pump it is not possible to exclude certain risks. The manufacturer does not accept any responsibility for any resulting damage.

**WARNING: powerful magnetic fields!**

Both the pump drive (magnet box) and the centrifugal pump heads (and the adapter SP-03) incorporate magnets which produce a powerful magnetic field. Any magnetically sensitive objects such as magnetic data storage media (magnetic tapes, diskettes, etc.) or watches should be kept away in order to avoid damage!

**Residual risks**

- The handling of chemicals is not within the responsibility of the manufacturer.
- The pump head must only be changed while the pump is switched off.
- Tubing has a certain permeability to gases depending on material and pressure conditions; it can also acquire static charges. We are warning of possible dangers if any tubing is run in hazardous areas.
- Where damage may be caused by leakage of liquid following a tubing burst, the necessary safety precautions must be taken before start-up.
- Do not carry out any manipulation on the pump head before the pump has been switched off.
- The pump head must be filled with the pumped liquid before start-up.

**IMPORTANT:**

Pump heads must never be run dry! Danger of bearing damage!

**Warranty**

From date of shipment

- drive BVP-BP: 2 years
- pump head: according to pump head manufacturer's information

In case of any doubt please contact your supplier.

**Warranty conditions**

We warrant the correct function of the BVP-BP drive provided it has been properly connected up and operated according to the guidelines of our Operating Instructions. Where it is shown that there are manufacturing or material faults, the faulty parts are rectified or replaced at our choice. Pump heads are subjected to the warranty conditions of the pump head manufacturer. The warranty period is not affected by any warranty claim. Additional claims are excluded. Freight charges have to be borne by the customer.

Our warranty becomes void if:

- the unit is operated incorrectly or used for any purpose other than as intended,
- any work is carried out on the unit or it is modified, an unsuitable location is chosen for the unit,

- the unit is used under environmental and/or electrical conditions for which it is not intended,
- software, hardware, accessories or consumables are used which do not conform to our specification,
- leakage of liquid following a tubing burst produces contamination which leads to damage.

**List of items supplied**

- drive BVP-BP
- mains supply cable
- Operating Instructions

Accessory if ordered:

- pump head

Please check the packaging and the contents for transport damage. If you find any signs of damage please contact the supplier immediately.

Any claims can only be entertained within 8 days from receipt of the goods.

**Operating panel**

- 1 Mains switch
- 2 Signal lamp
- 3 Speed selector (DigiPot), 999 = 3000 rpm (max. speed) = 50 rev/sec, adjustable in 0.1% steps
- 4 Start (RUN), stop (STOP)
- 5 MAX key for maximum speed (ideal for filling or emptying the system)

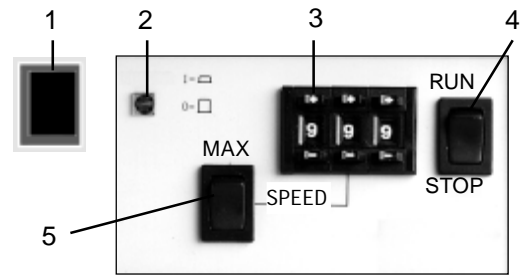

Operating panel

**PLEASE NOTE:**

**The drive runs clockwise only.**

**Back of unit**

- 6 Fan
- 7 Fuse holder with voltage selector 115V/230V
- 8 Power supply socket
- 9 Analogue interface connector
  - RUN / STOP (TTL)
  - speed control  
0 - 5 V or 0 - 10 V, or  
0 - 20 mA or 4 - 20 mA
  - speed output 0 - 5 V DC or 0 - 6 kHz

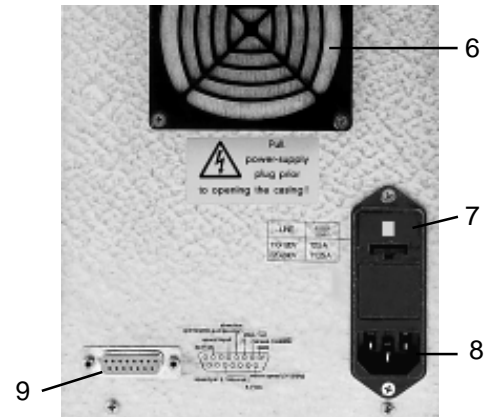

Back of unit

**Supply voltage**

Supply voltage	Nominal	Fuse
220-240 V <sub>AC</sub>	230 V 50/60 Hz	2 x 1.25 A T
110-120 V <sub>AC</sub>	115 V 50/60 Hz	2 x 2.50 A T

**⚠ Before start-up**

Check that the voltage selector indication in the window (10) of the fuse holder corresponds to your local supply voltage.

If necessary the setting has to be altered and the two fuses have to be changed.

**⚠ Supply socket / mains supply cable**

Use only the original cable supplied. The supply socket must be earthed (protective earth contact).

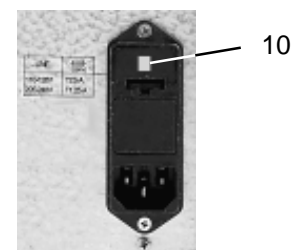

Checking the supply voltage setting

### Altering the supply voltage 115V/230V and changing the fuses.

ⓘ Switch off the pump, pull out the power supply plug!

- 1 Release the fuse holder with a small screwdriver and pull it out.
- 2 Take out the voltage selector plate and refit it with the required voltage setting towards the window in the fuse holder.
- 3 Fit two new fuses:
  - ⓘ on 230 V: 2 x 1.25 A T (slow blow)
  - ⓘ on 115 V: 2 x 2.5 A T (slow blow)

⚠ Always fit two fuses (slow blow) of the same type in accordance with the local supply voltage.

- 4 Close the fuse holder. The voltage setting is visible in the window.

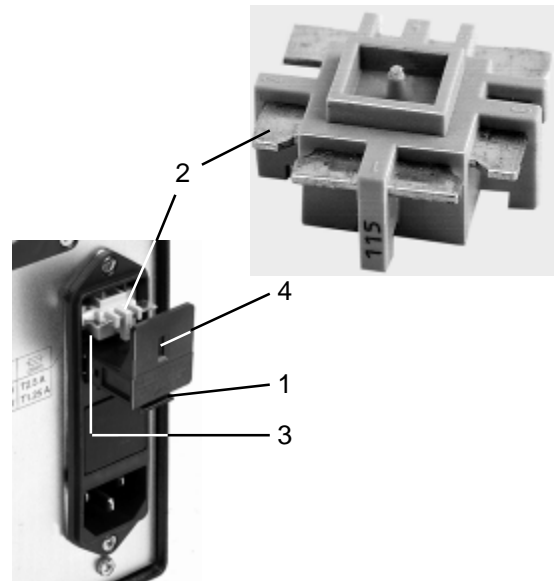

Changing supply voltage 115V/230 V and changing fuses

### Starting up

- Before starting up, fill the pump head with liquid. The pump head must not be running dry.
- Check the supply voltage in the window of the fuse holder (back of unit). If necessary alter it as described above.
- As required fit pump head according to page 8 or 10.
- Fit tubing and connect to the system.
- If necessary, secure the tubing with tubing clips or cable ties against slipping off.
- Connect the pump to the electrical supply.
- Before starting up, fill the pump head with liquid.

### Switching on

- 1 Mains switch ON
- 2 Signal lamp lights up.
- 3 Set the required speed on the DigiPot (999 = 3000 rpm).

ⓘ The speed can be altered while the pump is running.

- 4 Start the pump with the RUN/STOP key
- 5 While the pump is running, the MAX key can be used for rapid filling (or emptying) of the system.

⚠ **The pump head must not be running dry.**

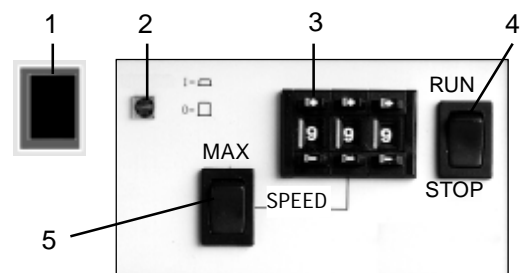

Switching on the unit

**Analogue interface connector**

**Pin 1 Ground**

Reference potential for all inputs and outputs.

**Pin 2 Remote**

Switching over between manual operation and the analogue interface. To activate the analogue interface, connect pin 2 to pin 1 (ground).

**Pin 3 Start / Stop**

The pump starts up on connecting to pin 1 (ground).

**Pin 5 Analogue Input**

External speed control (0-5 V, 0-10 V, 0-20 mA, 4-20 mA). Selection by internal DIP switch (see under Internal Adjustments).

**Pin 7 Supply**

Approx. +36 V DC (unstabilised) is available (max. load 1 A).

**Pin 9 (Output) Motor Speed**

The factory setting is 0-5 V DC proportional to motor speed 0-3000 rpm. As an alternative a frequency range 0-6 kHz is available. Selection by internal slide switch (see below).

**Internal adjustments**

To make the adjustments the casing has to be opened!

**⚠ The casing must only be opened by a properly qualified person!**

Live parts inside the casing may remain live for some time after the power supply plug has been pulled out.

**Opening the casing (taking off the top metal casing):**

Check before opening that the pump has been disconnected from the electrical supply.

To remove the metal casing, four screws (2 each right and left) have to be unscrewed. Switches S1 and S2 are then accessible.

Note: during removal and re-assembly be careful not to damage the yellow-green ground wire to the casing!

**DIP selector S2:**

This selector determines the form of external speed control (pin 5).

**Settings selector S2 (DIP switches)**

Pins		DIP-Switch 1	DIP-Switch 2	DIP-Switch 3	DIP-Switch 4	DIP-Switch 5	DIP-Switch 6
Pin 5 speed IN	0-5V	ON	OFF	OFF	OFF	OFF	ON
	0-10V	OFF*	ON*	OFF*	OFF*	OFF*	ON*
	0-20mA	OFF	OFF	ON	OFF	ON	ON
	4-20mA	OFF	OFF	OFF	ON	ON	OFF

\* Normal setting when shipped from the factory

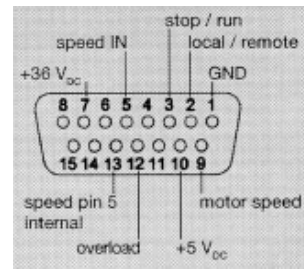

15-pin socket of analogue interface

TTL contacts: RUN/STOP

Input: 0-5 V, 0-10 V, 0-20 mA, 4-20 mA

Output: 0-5 V DC, 0-6 kHz (speed)

**Pin 10**

is connected to the stabilised +5 V DC supply voltage of the pump.

**Pin 12 Overload Status**

In case the drive is overloaded, this pin (open collector) is connected to ground.

Switch off the supply and allow the unit to cool down for 2 minutes.

**Pin 13**

If pin 13 is connected to pin 1 (ground), the speed can be set with the speed selector on the operating panel instead of by the signal on pin 5.

**Slide switch S1:**

This switch affects pin 9, OUT

Position **A**: 0-5 V DC (normal setting)

Position **B**: 0-6 kHz

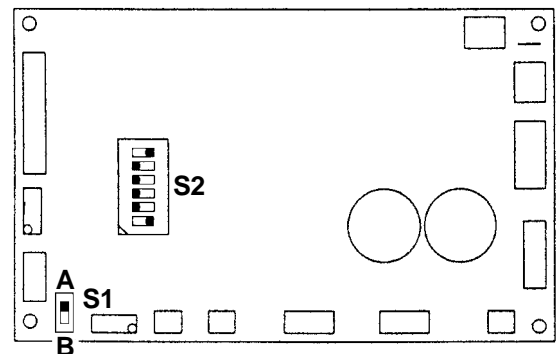

Position of selectors S1 and S2 on the printed circuit board

### Centrifugal pump heads

The pump heads described below are specially designed for pumping blood or erythrocyte suspensions. The heads BP-50 and BP-80 (Medtronic) can be fitted directly on to the holder of the pump drive, while Type SP-45 (Terumo) requires an adapter (SP-03) for operation.

NOTE: the information given below refers only to the special application of the heads in conjunction with the BVP-BP drive. It does not replace the Operating Instructions supplied with these heads.

The pump heads are hermetically sealed, there is no drive shaft taken to the outside. The drive is transmitted through a magnetic coupling. A ring-shaped permanent magnet is located inside the head which is coupled to a similar magnet of the pump drive. Rotation of the drive is transmitted to the pump rotor through the attraction force of the magnets.

### Pump head BP-50 and BP-80

The pump heads BP-50 and BP-80 (manufacturer: Medtronic) are specially designed for pumping blood or erythrocyte suspensions. The BP-50 differs from the BP-80 by having a filling volume of 50 ml compared with 80 ml, and also by a lower throughput. The diameter of the connections is also chosen suitable for the flow rate: BP-50 6.4 mm, BP-80 9.5 mm.

A pump head BP-80 is shown alongside at the top. Details and pumping function can be seen from the sectional drawing below. The drive fitted with the pump head is illustrated on the next page.

The cone-shaped vanes mounted above each other can rotate about a central bearing and are mechanically coupled to the magnet ring. Rotation of the rotor causes the liquid inside the head to rotate through surface friction and to be forced outward by the resulting centrifugal force towards the outlet connection. The resulting pressure-flow diagram is shown in Diagram 1 plotted against rotational speed.

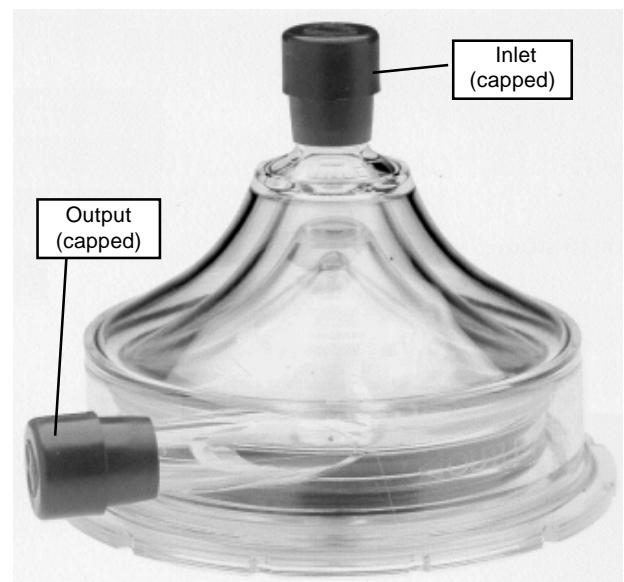

Pump head BP-80

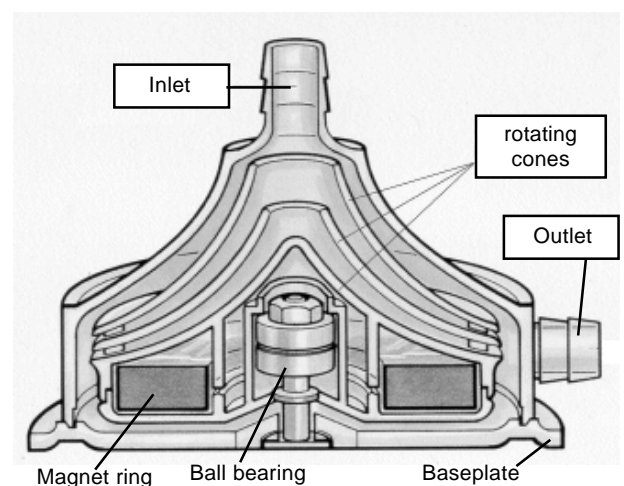

Pump head BP-80, section

### Output characteristic of a BP-80

Diagram 1 shows the flow-pressure characteristic of the combination BVP-BP with pump head BP-80 at varying speed settings. At each speed a particular pressure was produced by squeezing the tubing and the flow was measured. Normal tap water was used as liquid during the measurement.

The pressure-flow diagram shows that there is no exact linear relationship between speed and flow or pressure.

NOTE: the pressure/flow values which can be read from Diagram 1 must be taken only as average values and cannot not be guaranteed!

**Pulsation:** the pump head BP-80 (as well as the similarly designed but smaller BP-50) produces no pulsations in the flow of the liquid output!

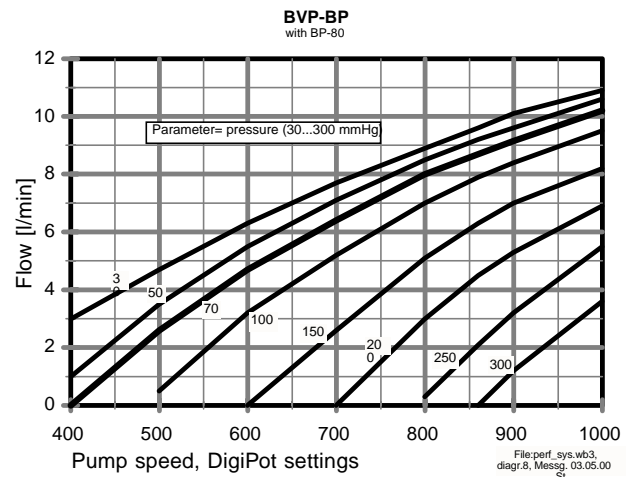

**Diagram 1:** Output with pump head BP-80 plotted against pump speed setting

### Fitting and removing the BP-80

When fitting or removing the pump head the drive unit must be switched off!

The baseplate of the pump head is inserted from above into the slot between magnet box and pressure plate, and pushed down up to the stop. The head must then be rotated so that the locking pin engages with one of the recesses in the rim. The tubing connection for the outlet should point to the right (as shown in the illustration alongside) so that the pump head can be vented when assembled (escape of trapped air).

To remove the head, tilt it slightly forward and then pull it upwards out of the holder.

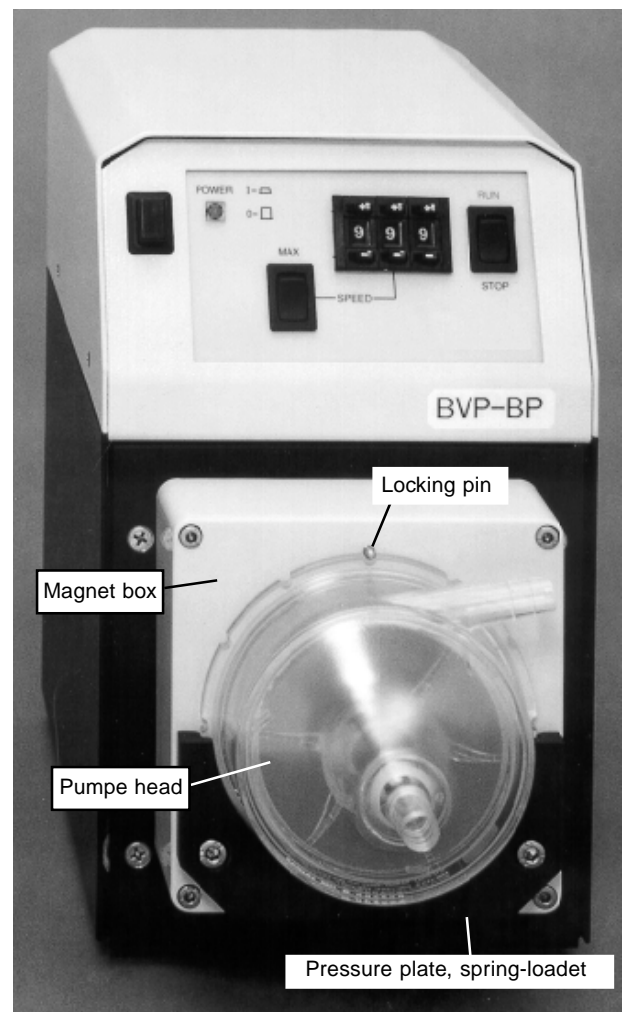

BVP-BP fitted with pump head BP-80



## Pump head SP-45

The pump head SP-45 (manufacturer: Terumo) is specially designed for pumping blood or erythrocyte suspensions. Operation of the head with the BVP-BP drive requires the use of the adapter SP-03.

A pump head SP-45 is shown alongside at the top. The drive fitted with the pump head is illustrated on the next page.

The function of the head differs slightly from that the Types BP-50/80 described before. The rotor does not consist of several rotating conical vanes but of a flat rotating disc which carries 6 ribs. The ribs have a special shape so that very little turbulence is produced during pumping.

The rotor disc rotates about a central bearing and is coupled mechanically to the magnet ring. As the rotor rotates, the liquid inside the head is carried along by the ribs and also made to rotate. The centrifugal force produced pushes the liquid to the outside towards the outlet connection. The resulting pressure-flow diagram is shown in Diagram 2 plotted against rotational speed setting.

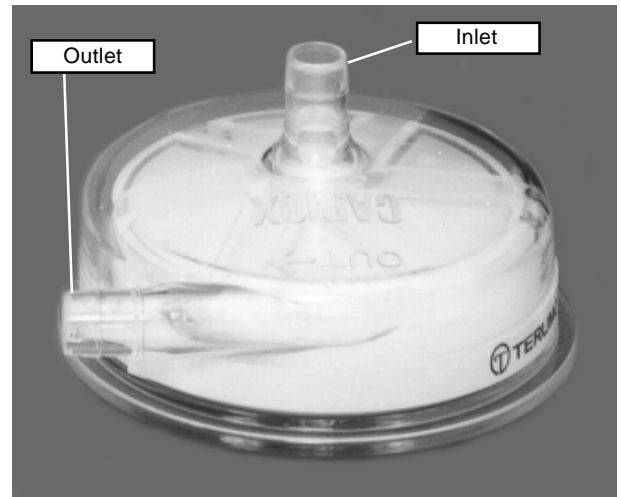

Pump head SP-45

## Output characteristic of SP-45

Diagram 2 shows the flow-pressure characteristic of the combination BVP-BP with pump head SP-45 at varying speed settings. At each speed a particular pressure was produced by squeezing the tubing and the flow was measured. Normal tap water was used as liquid for the measurement.

The diagram shows that there is not exact linear relationship between speed and flow or pressure.

NOTE: the pressure/flow values which can be read from Diagram 2 must be taken only as average values and cannot not be guaranteed!

**Pulsation:** the pump head SP-45 produces slight pulsations during pumping which are evidently caused by the ribs on the rotor. The pulsation rate depends on the rotor speed. At the maximum speed setting of 3000 rpm the pulsation has a frequency of 300 Hz.

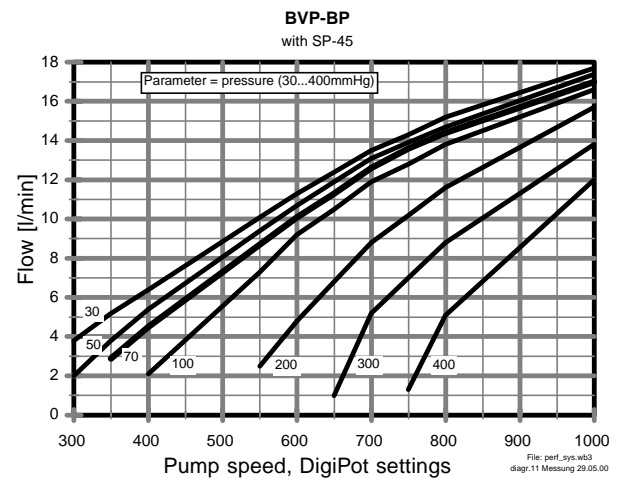
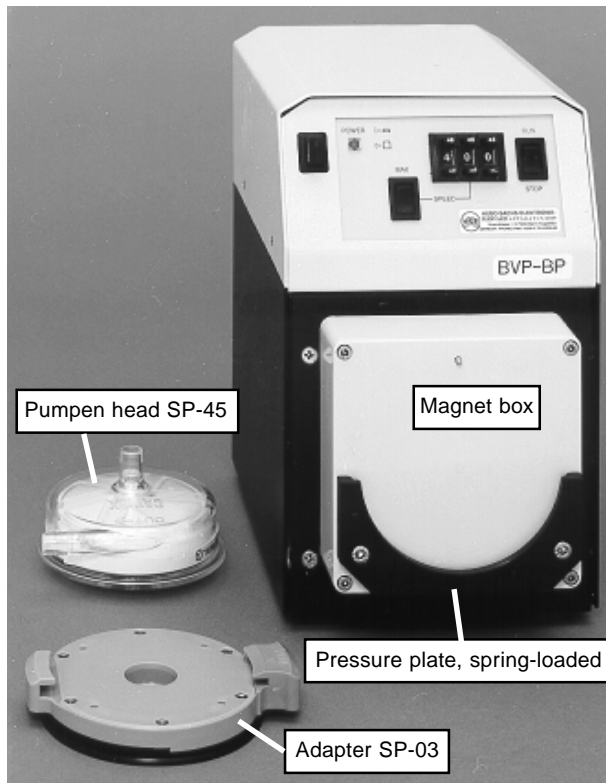

Diagram 2: Output with pump head SP-45 plotted against pump speed setting



Drive unit BVP-BP with pump head SP-45 and adapter SP-03



BVP-BP fitted with pump head SP-45

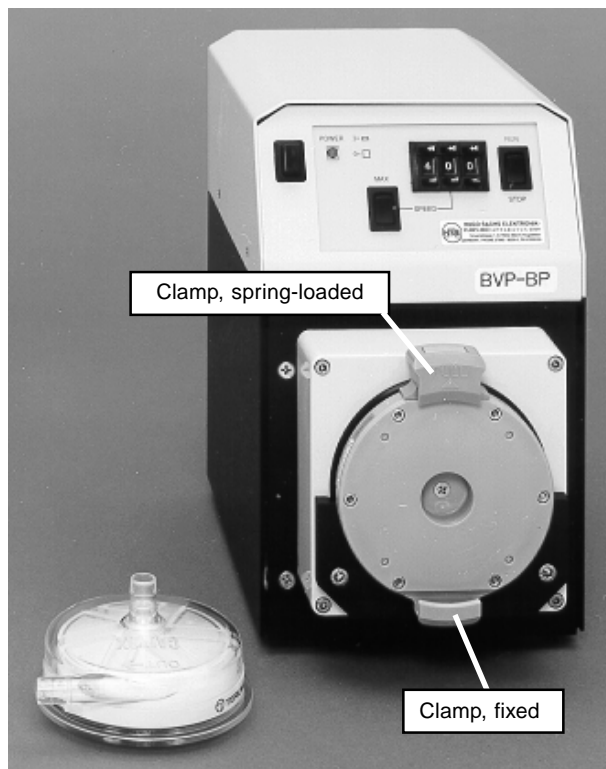

BVP-BP fitted with adapter SP-03

### Fitting the adapter SP-03 for head SP-45

Switch off the unit during fitting operation!

The baseplate of the adapter is inserted from above into the slot between magnet box and pressure plate and pushed down up to the stop. The spring-loaded clamp for the pump head must be at the top (see illustration alongside!).

### Inserting the pump head SP-45

Insert the pump head into the groove of the bottom fixed clamp, lift the top movable clamp against its spring-loading and allow the head to be attracted by the magnetic force of the adapter. If you now release the spring-loaded clamp it should spring back into its initial position and secure the head on the adapter. Ensure that the outlet connection is at the top and points to the right (see illustration above). There is no provision for stopping rotary movement between head and adapter.

To **remove** the head it is only necessary to lift the spring-loaded clamp on the adapter. The head can then be removed to the front.

## Operating notes

### Before switch-on

Ensure that the pump head is filled with the liquid to be pumped before you switch on. Operating the pump head dry may damage the rotor bearing.

### Pumping against pressure

The maximum flow rate depends on the back pressure and on the type of pump head used (see Diagrams 1 and 2).

### Speed setting

In order to keep haemolysis low you should not set a higher speed than is necessary. Do not artificially increase the flow resistance (squeezing the tubing) in order to achieve a certain flow rate.

### Faulty operation

As described above, the coupling of the drive to the pump rotor takes place through the attraction between the magnets. The coupling force is sufficient for all normal operations as long as the coupling does not become „disengaged“, e.g. through a sudden starting of the drive motor. The coupling can also become disengaged by careless handling of the tubing so that the pump head (or adapter) briefly does not lie properly against the magnet box of the drive. If drive and pump head have become „out of step“ this becomes evident by a loud rattling or whirring noise.

In this case switch off the drive briefly, allow it to come to rest, and switch it on again.

### Before switching off the pump

**⚠** When stopping the pump drive it is possible that the liquid flows back if a non-return valve is not fitted on the outlet side!

### Stopping the pump

If the pump will be out of use for some time it is essential to clean the pump head thoroughly (see under „Cleaning“).

### Repairs

For repairs please send the faulty BVP-BP drive back to your supplier.

Please state fault, purchase date, serial number and type.

### Spares

For repairs outside the warranty period you can contact your supplier to obtain spare parts, list of items, wiring diagrams. Please state fault, purchase date, serial number and type.

## Maintenance and cleaning

The drive does not require any special maintenance. Any dirt on the casing should be removed immediately. A cloth moistened with water should be used for cleaning. With strongly adhering dirt you can add a little cleaning solution (domestic detergent) to the water.

### WARNING:

- Before starting any cleaning operation pull out the power supply plug
- Do not allow any liquid to pass into the casing

We recommend thorough cleaning of the pump head after each application:

- first wash out with normal tap water
- with proteins in the liquid, wash again with acetic acid (5%)
- use distilled water for a final rinse.

The pump heads have to be considered as consumable items with a limited life. Especially the internal seal („Simmerring“ seal) of the rotor bearing is endangered if

- the pump head is operated dry, or
- unsuitable cleaning agents are used, or
- the cleaning agent is left inside the head for too long.

If the pump is being used as intended and with the necessary care, only the moving parts are subjected to a certain amount of wear.

## Technical data

Drive motor type:	DC motor
Speed range:	60 - 3000 rpm = 50 rev/sec, adjustable in 0.1% steps
Flow rate and pressure:	depending on pump head
External control:	via analogue interface (see page 6)
Supply:	115 V (50/60 Hz) or 230 V (50/60 Hz)
Fuses:	2 x 2.5 A T (slow blow) at 115 V or 2 x 1.25 A T (slow blow) at 230 V
Power:	150 W max.
Protection:	IP 30
Operating conditions:	normal laboratory environment temperature +5 to +40°C rel. humidity 80% max.
Dimensions (drive):	DxWxH 220x155x260 mm
Weight:	5.7 kg
CE conformity:	approved to EN 50081-1/ EN 50082-2/EN 61010-1

**Reply form**

Please take a few minutes of your time in order to write to us on any difficulties in understanding the Operating Instructions or in the use of the apparatus. With your feedback you will help to improve our products and the system documentation and make them more user-friendly.

Please tell us

- ☞ where you have found mistakes,
- ☞ where the arrangement was not clear and what you did not understand,
- ☞ and where you would like to see improvements.

Many thanks for your kind assistance.

Yours HUGO SACHS ELEKTRONIK - HARVARD APPARATUS GmbH.

Your name \_\_\_\_\_

Organisation \_\_\_\_\_

Street \_\_\_\_\_

Town \_\_\_\_\_

Phone/Fax \_\_\_\_\_

e-mail \_\_\_\_\_

\_\_\_\_\_

\_\_\_\_\_

\_\_\_\_\_

\_\_\_\_\_

\_\_\_\_\_

\_\_\_\_\_

\_\_\_\_\_

\_\_\_\_\_

\_\_\_\_\_

\_\_\_\_\_

\_\_\_\_\_

Please send this sheet or a copy to:

Hugo Sachs Elektronik - HARVARD APPARATUS GmbH, Gruenstr. 1, D-79232 March-Hugstetten, Germany  
Fax. (int. + 49) 7665-9200-90

## Index

### A

acetic acid (5%) ... 11  
 adapter SP-03 ... 9, 10  
 Analogue interface ... 4, 6  
 application range ... 2

### B

blood, pumping ... 7, 9  
 BP-50 ... 7, 8  
 BP-80 ... 7, 8

### C

cable, mains supply ... 4  
 casing, opening the ... 6  
 centrifugal force ... 7, 9  
 circuit board ... 6  
 claims ... 3  
 clamp, fixed ... 10  
 clamp, spring loaded ... 10  
 Cleaning ... 11  
 cones ... 7  
 connections ... 7  
 coupling force ... 11

### D

Diagram, pressure flow ... 9  
 Diagram, pressure-flow ... 8  
 DigiPot ... 4, 5  
 DIP switch ... 6  
 disc, rotating ... 9  
 distilled water ... 11

### E

earth contact, protective ... 4  
 emptying, rapid ... 5  
 erythrocyte suspension ... 7, 9

### F

Faulty operation ... 11  
 filling, rapid ... 4, 5  
 Fitting the adapter ... 10  
 Fitting the head ... 8  
 friction, surface ... 7  
 fuse holder ... 4, 5  
 fuses ... 5

### G

GLP ... 2

### H

haemolysis ... 11  
 hazardous areas ... 3

### I

internal adjustments ... 6

### L

locking pin ... 8

### M

magnet ... 2, 3, 7, 9, 10  
 magnet box ... 8, 10  
 magnetic field ... 3  
 Mains switch ... 4, 5  
 maintenance ... 11  
 manufacturer's details ... 2  
 MAX key ... 4, 5  
 medical applications ... 2  
 Medtronic ... 2, 7  
 motor speed ... 6

### N

non-return valve ... 11

### O

operating notes ... 11  
 output of overload ... 6  
 Overload ... 6

### P

Power supply socket ... 4  
 Pressure plate ... 8, 10  
 pressure-flow diagram ... 8, 9  
 proteins in liquid ... 11  
 Pulsation ... 8, 9  
 Pump ... 8, 9  
 Pump head BP-50 ... 7  
 Pump head BP-80 ... 7  
 pump head BP-80 ... 8  
 pump head SP-45 ... 9, 10  
 pump rotor ... 7  
 pumping against pressure ... 11  
 pumping blood ... 7, 9

### R

repairs ... 2, 11  
 ribs on pump rotor ... 9  
 risks, residual ... 3

### S

safety precautions ... 2  
 socket, 15-pin ... 6  
 SP-03 ... 10  
 SP-45 ... 9, 10  
 Spares ... 11  
 speed control ... 6  
 speed, motor OUT ... 6  
 speed setting ... 4, 5, 11  
 supply ... 6  
 supply voltage, altering the ... 5  
 surface friction ... 7  
 switching on ... 5

### T

Terumo ... 2, 7, 9  
 turbulence ... 9

### V

valve, non return ... 11  
 voltage selector ... 4, 5  
 voltage selector indication ... 4  
 voltage setting ... 5

### W

WARNING ... 3  
 Warning note ... 3  
 wash ... 11  
 window (115/230 V) ... 4, 5